



RUNAU

Jiangsu Runau Electronics Manufacturing Co.,Ltd

MDC500 MDA500 MDK500 MDX500

1200-2000V_{RRM}

GENERAL PURPOSE DIODE MODULE

Features:

- . Electrical insulation between chip and base plate, 2500V AC insulation
- . Compact structure
- . Excellent temperature characteristics and power cycling capability
- . Small size & light weight

Typical application:

- . AC / DC motor control
- . Various rectification power supplies
- . Frequency converter



ELECTRICAL CHARACTERISTICS AND RATINGS

Symbol	Parameter	Conditions	Tj(°C)	Data			Unit
				Min	Typ	Max	
I _{F(AV)}	Mean forward current	Sinewave 180°,50Hz Single side cooling, Tc=85°C	150			500	A
I _{F(RMS)}	RMS forward current		150			785	A
V _{RRM}	Repetitive peak off-state voltage Repetitive peak reverse voltage	V _{DRM} &V _{RRM} tp=10ms V _{DSM} &V _{RSM} =V _{DRM} &V _{RRM} +200V	25	800		1800	V
I _{RRM}	Repetitive peak off-state current	V _{DM} = V _{DRM} V _{RM} = V _{RRM}	150			30	mA
I _{RRM}	Repetitive peak reverse current						
I _{FSM}	Surge forward current	10ms bottom width, half sine wave V _R =0.6V _{RRM}	150			21	KA
I ² t	I squared t					2250	A ² s*10 ³
V _{FO}	Forward threshold voltage		150			0.75	V
r _F	Slope resistance					0.32	mΩ
V _{FM}	Peak forward voltage	I _{FM} =1500A	25			1.30	V
R _{th(j-c)}	Thermal impedance(junction to case)	180°sine wave, Single side heat dissipation				0.090	°C /W
R _{th(c-h)}	Thermal impedance(case to heatsink)	180°sine wave, Single side heat dissipation				0.024	°C /W
V _{iso}	Insulation voltage	50Hz, R.M.S, t=1min, I _{iso} : 1mA(MAX)		2500			V
F _m	Electrode mounting torque (M6)					12	N·m
	Base plate mounting torque (M6)					6	N·m
T _{stg}	Storage temperature			-40		125	°C
W _t	Weight					1570	g

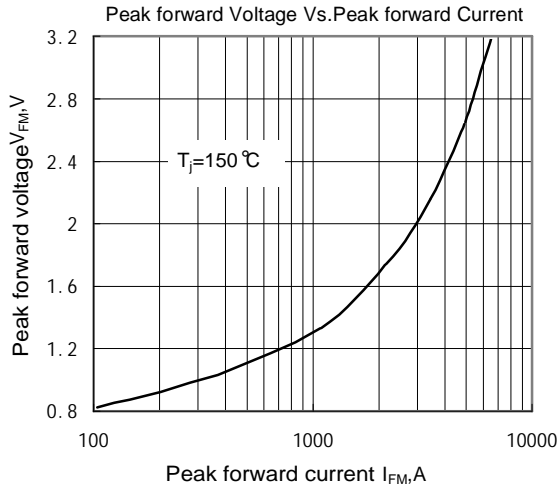

Fig.1 Forward Volt-ampere Characteristic Curve

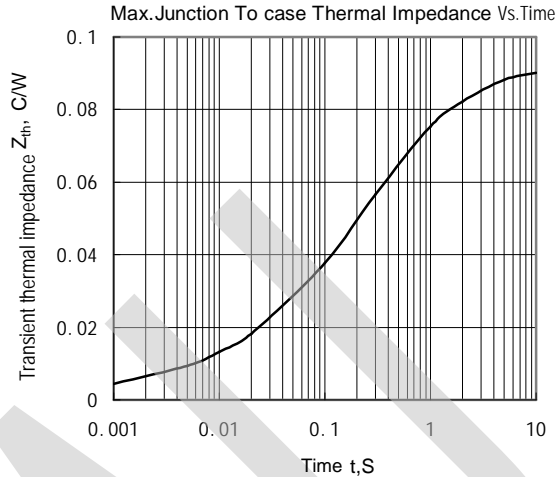

Fig.2 Transient Thermal Impedance Curve

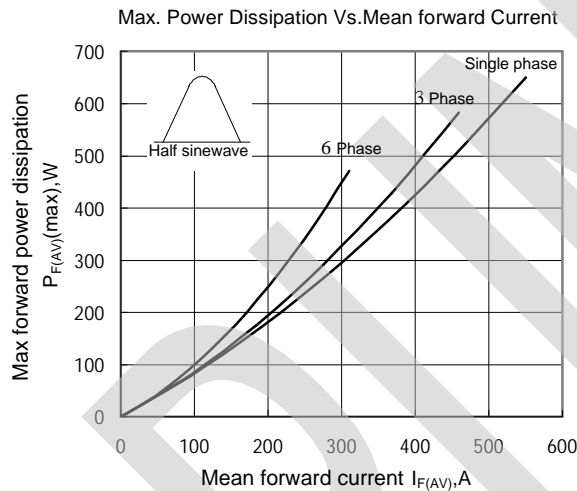

Fig.3 Max Power Dissipation Vs. Mean Forward Current

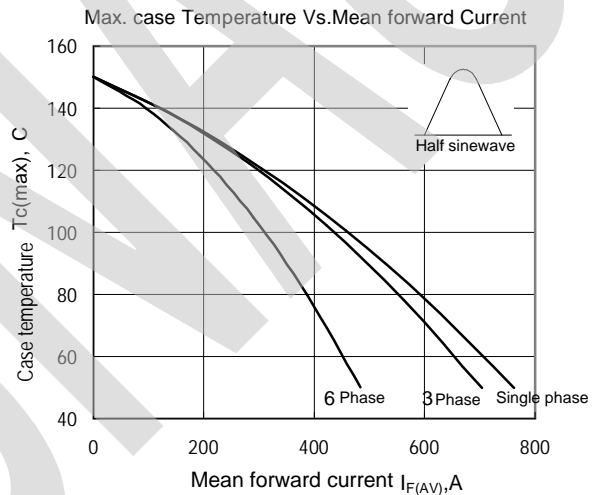

Fig.4 Max Case Temperature Vs. Mean Forward Current

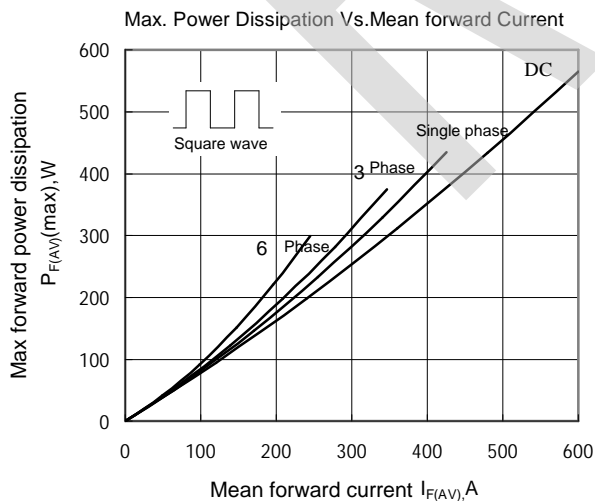

Fig.5 Max Power Dissipation Vs. Mean Forward Current

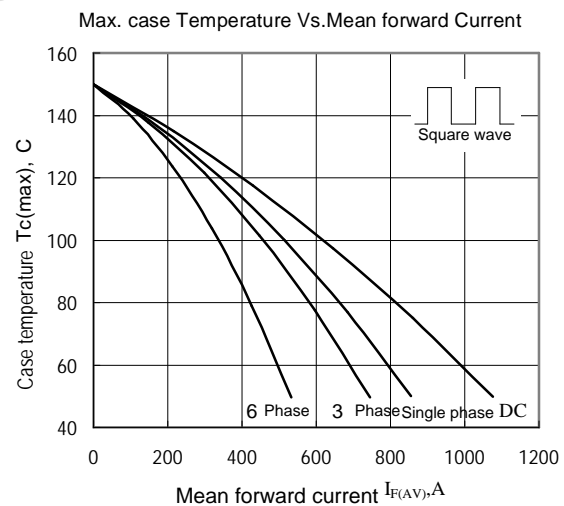

Fig.6 Max Case Temperature Vs. Mean Forward Current

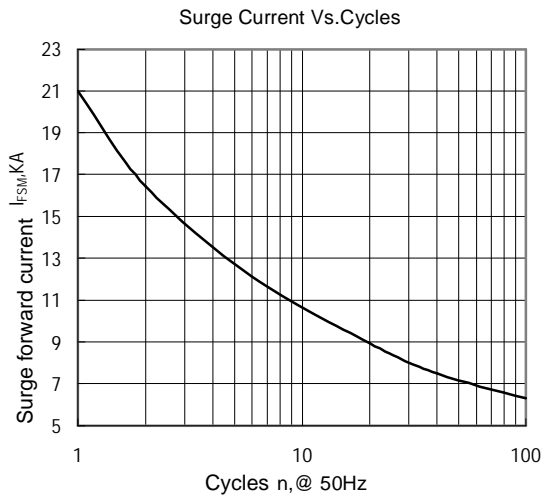

Fig.7 Surge Current Vs.Cycles

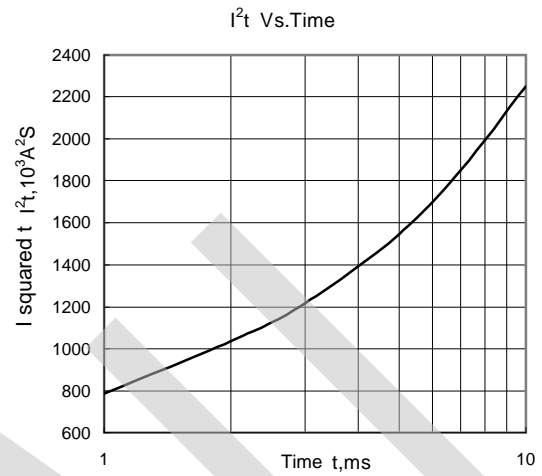
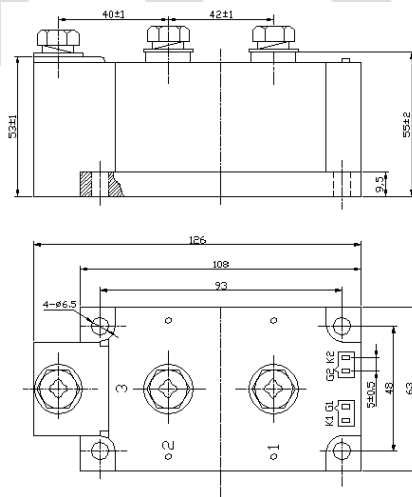

Fig.8 I²t Vs. Time

OUTLINE



M463F

