

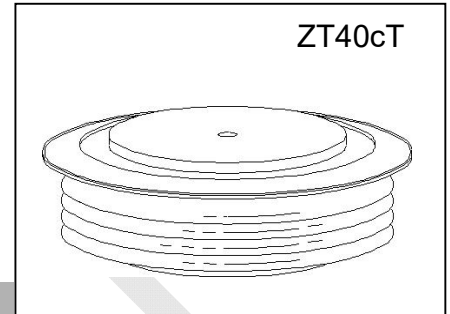

FAST RECOVERY RECTIFIER

Features:

- . All diffused structure
- . High surge rating
- . Blocking capability up to 1800 volts
- . Soft recovery
- . Ceramic housing hermetic package
- . Pressure assembled device



ELECTRICAL CHARACTERISTICS AND RATINGS

Reverse Blocking

Device Type	V _{RRM} (1)	V _{RSM} (1)
ZK800-10	1000	1100
ZK800-12	1200	1325
ZK800-14	1400	1525
ZK800-16	1600	1750
ZK800-18	1800	2000

V_{RRM} = Repetitive peak reverse voltage

V_{RSM} = Non repetitive peak reverse voltage (2)

Repetitive peak reverse leakage current	I _{RRM}	15 mA 35 mA (3)
---	------------------	--------------------

Notes:

All ratings are specified for T_j=25 °C, unless otherwise stated

- (1) All voltage ratings are specified for an applied 50Hz/60zHz sinusoidal waveform over the temperature range -40 to +125°C.
- (2) 10 msec. max. pulse width
- (3) Maximum value for T_j = 125°C.
- (4) See parameter definition below :

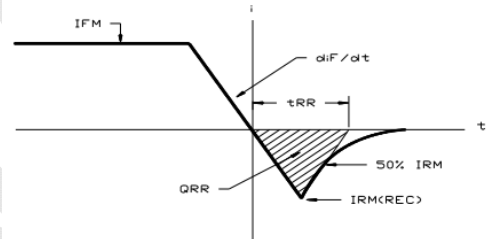

REVERSE RECOVERY CHARACTERISTIC

Conducting - on state

Parameter	Symbol	Min.	Max.	Typ.	Units	Conditions
Average forward current	I _{F(AV)}		800		A	Sinewave 180°, T _c = 115°C
RMS forward current	I _{FRMS}		1256		A	
Peak one cycle surge (non repetitive) current	I _{FSM}		9600		A	10 msec (50Hz), sinusoidal wave-shape, 180° conduction, T _j = 125°C
I square t	I ² t		460000		A ² s	8.3 msec and 10.0 msec
Peak forward voltage	V _{FM}		2.30		V	I _{FM} = 2400A; Duty cycle ≤ 0.01%
Reverse Recovery Current (4)	I _{RM(REC)}		*		A	I _{FM} = 1000 A; dI _F /dt = 10 A/μs; T _j max
Reverse Recovery Charge (4)	Q _{rr}		*		μC	I _{FM} = 1000 A; dI _F /dt = 10 A/μs; T _j max
Reverse Recovery Time (4)	t _{rr}		5		μs	I _{FM} = 1000 A; dI _F /dt = 10 A/μs; T _j max

* For guaranteed maximum values, contact factory

Parameter	Symbol	Min.	Max.	Typ.	Units	Conditions
Operating temperature	T_j	-40	+125		°C	
Storage temperature	T_{stg}	-40	+140		°C	
Thermal resistance - junction to case	$R_{\Theta(j-c)}$		0.039		°C/W	Double sided cooled (1) @ 2000 lb.; (2) @ 800 lb.
Thermal resistance - junction to case	$R_{\Theta(j-c)}$		0.078		°C/W	Single sided cooled (1) @ 2000 lb.; (2) @ 800 lb.
Thermal resistance - case to heatsink	$R_{\Theta(c-s)}$		0.008 0.016		°C/W	Double sided cooled * Single sided cooled *
Mounting force	P			15	kN	
Weight	W			260	g	

* Mounting surfaces smooth, flat and greaseless

CASE OUTLINE AND DIMENSIONS

